

# TELESCOPIC CYLINDERS

## Series RT

The overall dimensions are one of the most important aspects: in comparison with a traditional ISO cylinder of the same stroke a reduction in size of approx. 45% (with a 3-stage telescopic cylinder) is obtained thus permitting the customer to foresee a considerable reduction of the project and construction of his equipment. The cylinder can be supplied in magnetic version and with slide unit (only for 2-stage version).

### TECHNICAL CHARACTERISTICS

Working pressure: 1,5 ÷ 10 bar  
 Ambient temperature: -20°C ÷ 80°C  
 Fluid: filtered air, lubricated or not.  
 Barrel: in aluminium, internally/externally anodized.  
 Non-rotating rod in chromium-plated steel with standard supplied flange except for version with male rod.  
 Elastic bumpers.  
 Magnetic version with detection of position of the 1st stage only.

#### Upon request

- Magnetic sensor DF...
- Wire protection strap for magnetic sensor.
- Magnetic version 2-3 stages with telescopic magnet holder prearranged only for end-stroke reading (except for Ø 25 mm).
- Slide unit only for 2-stage telescopic cylinder.



Table summarizing bore combinations

Telescopic cylinder	Ø I° stage	Ø II° stage	Ø III° stage
25	25	16	-
32	32	20	-
40	40	25	16
50	50	32	20
63	63	40	25

#### Codification key

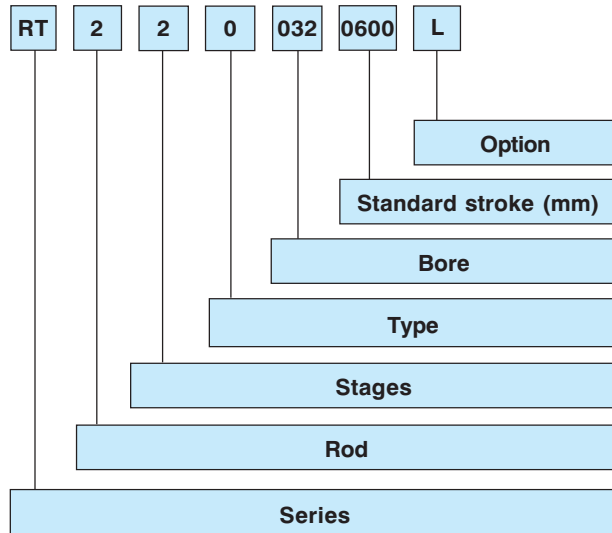

#### SERIES

Telescopic pneumatic cylinder in magnetic version with non-rotating piston rod, elastic bumpers and flange, Ø 025 ÷ 063 mm

#### ROD

- 2... chromium-plated steel
- 1... stainless steel

#### STAGES

- 2... 2 stages
- 3... 3 stages

#### TYPE

- 0 = D.A. inter-axes female rod with flange
- 3 = D.A. inter-axes male rod

#### BORE

- 2 stages: Ø 025-032-040-050-063 mm
- 3 stages: Ø 040-050-063 mm

#### STANDARD STROKE

- 2 Stages**  
0100-0120-0160-0180-0200-0300-0400-0500-0600-0700  
0800-0900-1000-1100-1200

- Max stroke:
- Ø 25 **0300 mm**
  - Ø 32 **0400 mm**
  - Ø 40 **0600 mm**
  - Ø 50 **0900 mm**
  - Ø 63 **1200 mm**

#### 3 Stages

- 0150-0180-0210-0240-0270-0300-0360-0450-0600-0750  
0900-1050-1200-1500-1800

- Max stroke:
- Ø 40 **1200 mm**
  - Ø 50 **1500 mm**
  - Ø 63 **1800 mm**

#### OPTION

- I = Without flange (only for female piston rod).
- L = Freely rotating rod.
- M = With telescopic magnetic holder for 2<sup>nd</sup>-3<sup>rd</sup> stage (except for Ø 25 mm). Only for TYPE 0 (=female piston rod with flange)

## 2-stage telescopic cylinders Theoretical forces in N (0,102 Kg)

2-stage telescopic cylinder	Useful surface (mm <sup>2</sup> )	Working pressure (bar)					
		2	4	6	8	10	
25	thrust	201	41	82	123	164	205
	traction	111	22	43	65	87	108
32	thrust	314	64	128	192	256	320
	traction	201	41	82	123	164	205
40	thrust	490	100	200	300	400	500
	traction	377	77	154	231	308	384
50	thrust	804	164	328	492	656	820
	traction	603	123	246	369	492	615
63	thrust	1256	256	512	769	1025	1281
	traction	1055	215	430	646	861	1076

## 3-stage telescopic cylinders Theoretical forces in N (0,102 Kg)

3-stage telescopic cylinder	Useful surface (mm <sup>2</sup> )	Working pressure (bar)					
		2	4	6	8	10	
40	thrust	201	41	82	123	164	205
	traction	111	22	43	65	87	108
50	thrust	314	64	128	192	256	320
	traction	201	41	82	123	164	205
63	thrust	490	100	200	300	400	500
	traction	377	77	154	231	308	384

### Maximum applicable torque [Nm] for non-rotating rod

Cyl. Ø	Torque	
	2 stages	3 stages
25	0,5	-
32	0,8	-
40	1	0,5
50	2	0,8
63	3	1

### Nominal tolerances on stroke (mm)

Cyl. Ø	Tolerance	
	2 stages	3 stages
25	+ 2/0	
32		
40	+ 3,2/0	+ 4/0
50		
63		

The telescopic cylinder works in optimal conditions when the load is axial, i.e. with the cylinder placed vertically, upwards or downwards. Naturally it can also work horizontally and cantilevered. However in this case:

- the maximum strokes have to be reduced by 50% as compared to the maximum rated ones.
- request cylinders with slide units.
- the radial load has to be supported by other systems (carriage, slides, sliding guides).

The following example shows the relation of dimensions between the cylinder types having the same stroke of 300 mm.

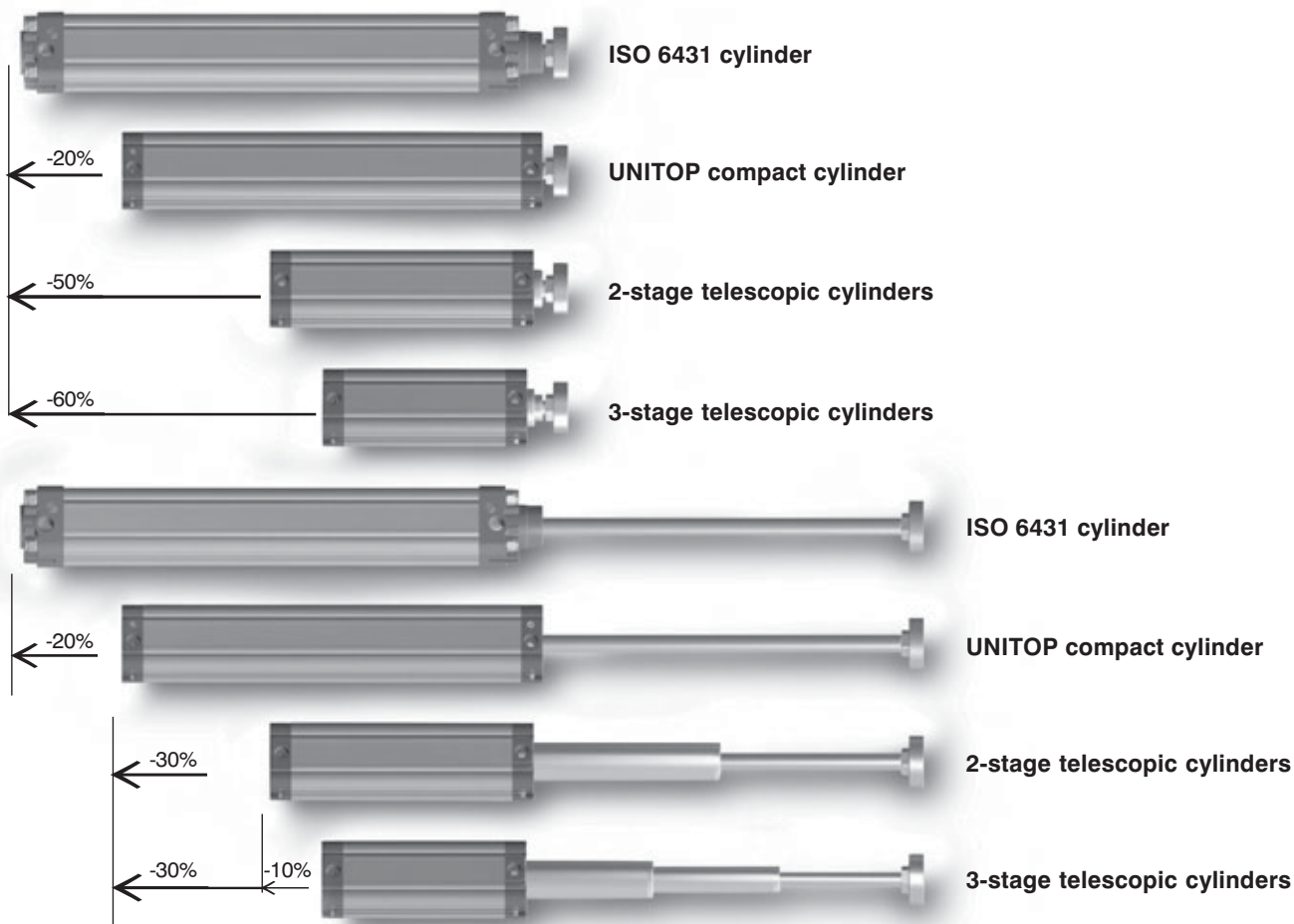

## 2- stage telescopic cylinder with flange RT220...

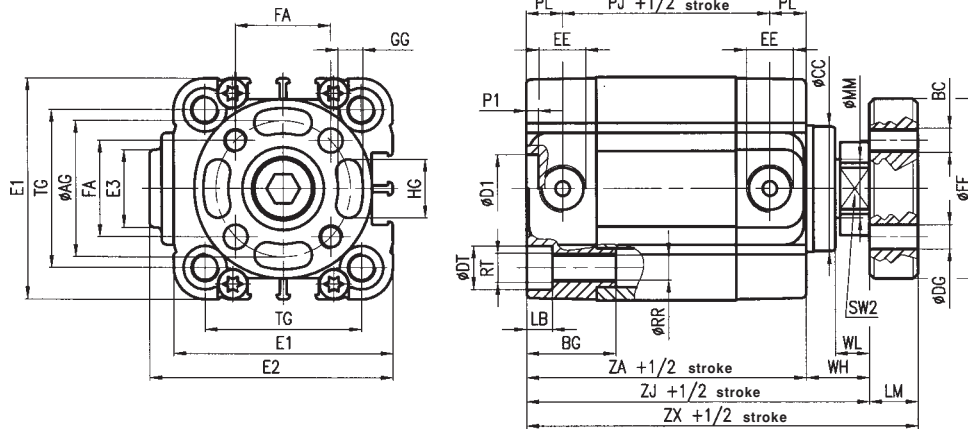

## 2- stage telescopic cylinder magnetic version RT220...M

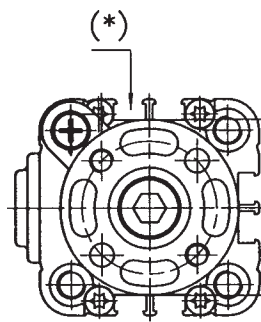

(\*) Note: the magnetic sensor DF... may only be placed near the telescopic magnet holder stem (as shown in the drawing).

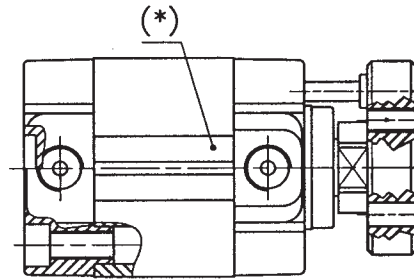

## 2- stage telescopic cylinder without flange RT220...I

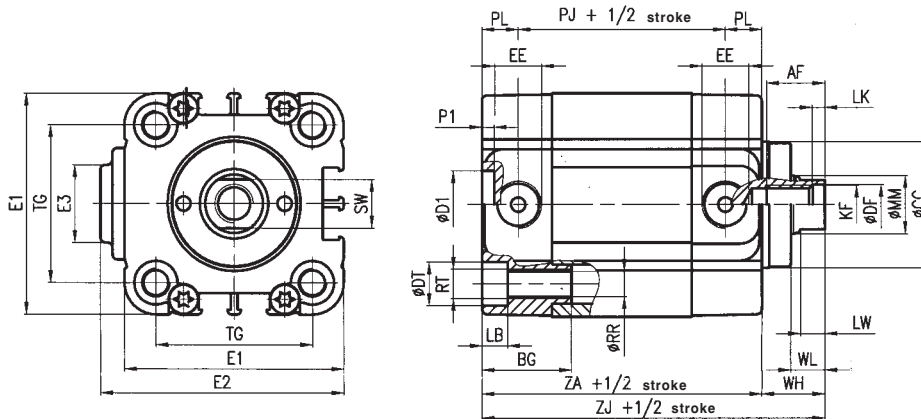

## 2- stage telescopic cylinder with male rod RT223...

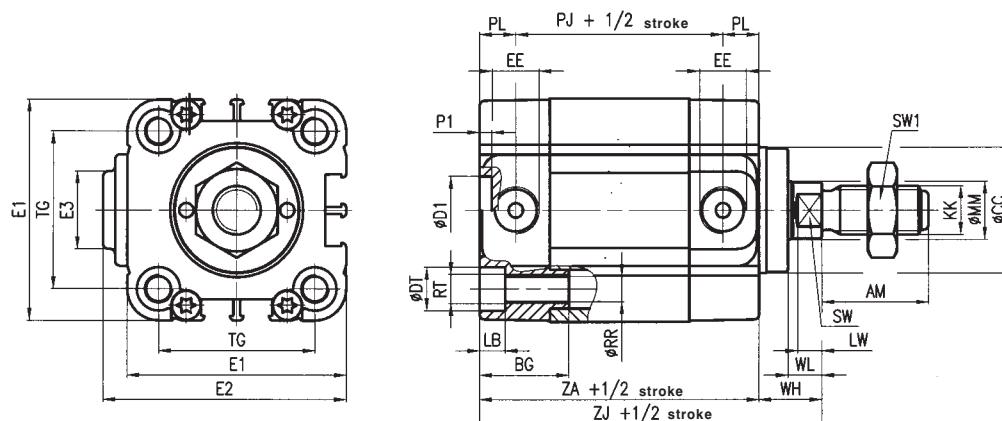

Cyl. Ø	AF	Ø AG	AM	BC	BG	Ø CC	ØD1 H11	Ø DF	Ø DG	Ø DT	E1	E2	E3	EE	FA	Ø FF	GG	HG	KF
25	10	22	22	M5	16	22	2	6,1	5	8	37	39	18	M5	15,6	30	5	9	M6
32	12	28	22	M5	18	26	14	8,2	5	9	46	50,5	16	G1/8	19,8	37	5,2	11	M8
40	12	33	22	M5	18	32	14	8,2	5	9	56	60,5	16	G1/8	23,3	42	5,2	15	M8
50	16	42	24	M6	24	40	18	10,2	6	11	66	70,5	16	G1/8	29,7	52	6,2	19	M10
63	16	50	24	M6	24	48	18	10,2	6	11	79	83,5	38	G1/8	35,4	64	6,2	25	M10

Cyl. Ø	KK	LB	LK	LM	LW	Ø MM	P1	PJ	PL	Ø RR	RT	SW	SW1	SW2	TG	WH	WL	ZA	ZJ	ZX
25	M10X1,25	4,5	1	8	4,5	10	2	32	8	4,2	M5	8	17	-	26	17	7	48	65	73
32	M10X1,25	5,3	2	10	5	12	2,5	43	7,5	5,2	M6	10	17	17	32,5	13	7	58	71	81
40	M10X1,25	5,3	2	10	5	12	2,5	45	7,5	5,2	M6	10	17	19	38	12	7	60	72	82
50	M12X1,25	6,5	2	12	6	16	2,5	46	7,5	6,6	M8	13	19	24	46,5	15	8	61	76	88
63	M12X1,25	6,5	2	12	6	16	2,5	50	7,5	6,6	M8	13	19	24	56,5	15	8	65	80	92

## Mass

### RT220...

Cyl. Ø	Cylinder "0" stroke (g)	Increase per mm stroke (g)	Moving parts "0" stroke (g)	Increase per mm stroke (g)
25	200	2,45	74,2	1,2
32	270	3,02	124,6	1,4
40	419	3,77	182	1,6
50	640	5,28	314	2,6
63	1005	6,33	480	2,72

### RT220...M

Cyl. Ø	Cylinder "0" stroke (g)	Increase per mm stroke (g)	Moving parts "0" stroke (g)	Increase per mm stroke (g)
32	245	3,02	137,6	1,5
40	380	3,77	188,5	1,7
50	572	5,28	318	2,7
63	910	6,33	487	2,8

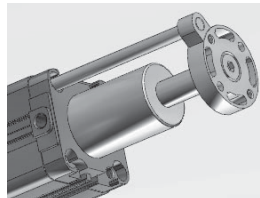

#### Option /M

= Always Female Piston Rod with Flange and Telescopic Magnetic Holder

### RT220...I

Cyl. Ø	Cylinder "0" stroke (g)	Increase per mm stroke (g)	Moving parts "0" stroke (g)	Increase per mm stroke (g)
25	238	2,45	67,2	1,2
32	245	3,02	99,6	1,4
40	380	3,77	142,5	1,6
50	572	5,28	246	2,6
63	910	6,33	385	2,72

### RT223...

Cyl. Ø	Cylinder "0" stroke (g)	Increase per mm stroke (g)	Moving parts "0" stroke (g)	Increase per mm stroke (g)
25	270	2,45	79,2	1,2
32	275	3,02	129,6	1,4
40	410	3,77	172,5	1,6
50	617	5,28	291	2,6
63	955	6,33	430	2,72

**3-stage telescopic cylinder with flange RT230...**

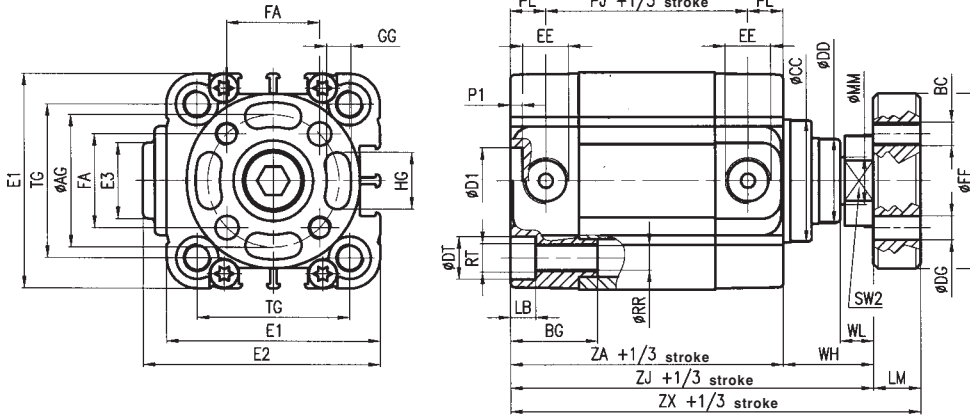

**3-stage telescopic cylinder magnetic version RT230...M**

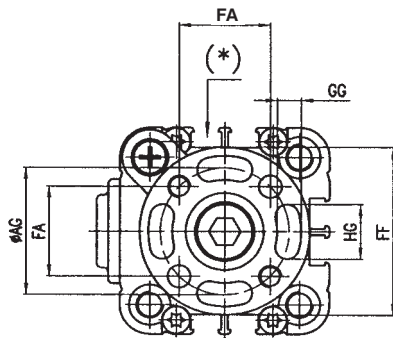

(\*) Note: the magnetic sensor DF... may only be placed near the telescopic magnet holder stem (as shown in the drawing).

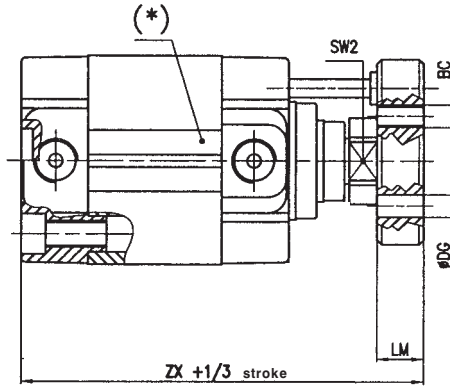

**3-stage telescopic cylinder without flange RT230...I**

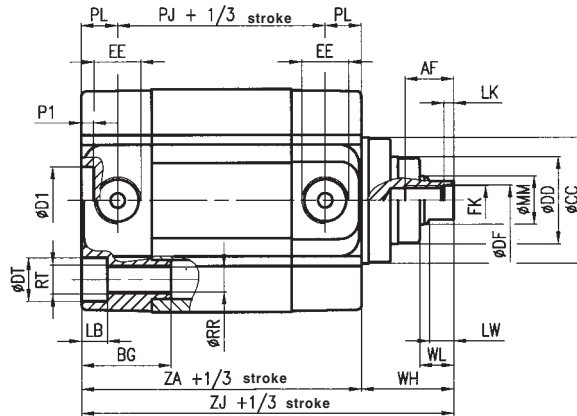
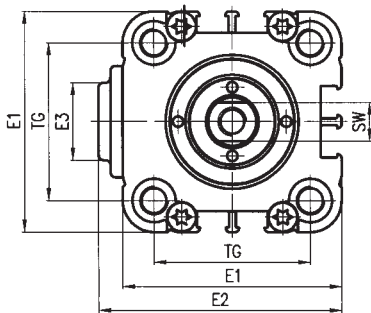

**3-stage telescopic cylinder with male rod RT233...**

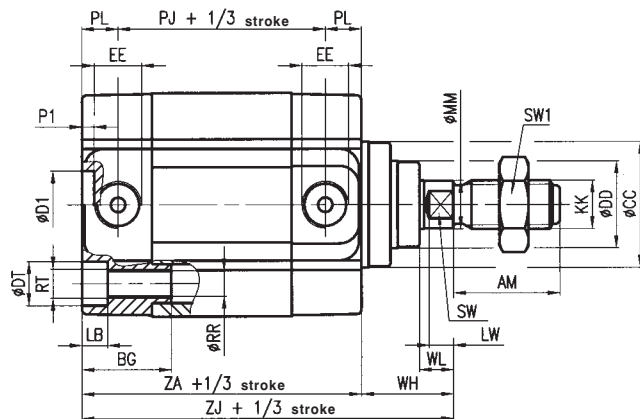
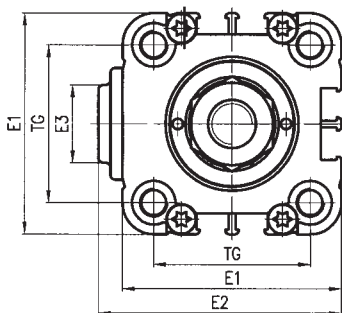

Cyl. Ø	AF	Ø AG	AM	BC	BG	Ø CC	ØD1 H11	Ø DD	Ø DF	Ø DG	Ø DT	E1	E2	E3	EE	FA	Ø FF	GG	HG	KF
40	10	28	22	M5	18	32	14	22	6,2	5	9	56	60,5	16	G1/8	19,8	37	5,2	11	M6
50	12	28	22	M5	24	40	18	26	8,2	5	11	66	70,5	16	G1/8	19,8	37	5,2	11	M8
63	12	33	22	M5	24	48	18	32	8,2	5	11	79	83,5	38	G1/8	23,3	42	5,2	15	M8

Cyl. Ø	KK	LB	LK	LM	LW	Ø MM	P1	PJ	PL	Ø RR	RT	SW	SW1	SW2	TG	WH	WL	ZA	ZJ	ZX
40	M10X1,25	5,3	2	10	5	10	2,5	45	7,5	5,2	M6	8	17	17	38	22	7	60	82	92
50	M10X1,25	6,5	2	10	5	12	2,5	46	7,5	6,6	M8	10	17	17	46,5	24	7	61	85	95
63	M10X1,25	6,5	2	10	5	12	2,5	50	7,5	6,6	M8	10	17	19	56,5	25	7	65	90	100

### Dimensional variations for RT230...M series

Cyl. Ø	Ø AG	BC	Ø DG	FA	Ø FF	GG	HG	LM	SW2	ZX
40	33	M5	5	23,3	42	5,2	15	10	19	92
50	42	M6	6	29,7	52	6,2	19	12	24	97
63	50	M6	6	35,4	64	6,2	25	12	24	102

## Mass

### RT230...

Cyl. Ø	Cylinder "0" stroke (g)	Increase per mm stroke (g)	Moving parts "0" stroke (g)	Increase per mm stroke (g)
40	399	3,9	162	1,75
50	591	5,07	265	2,37
63	939	6,34	417	2,75

### RT230...M

Cyl. Ø	Cylinder "0" stroke (g)	Increase per mm stroke (g)	Moving parts "0" stroke (g)	Increase per mm stroke (g)
40	374	3,9	191	2
50	553	5,07	306,5	2,62
63	871	6,34	459	3

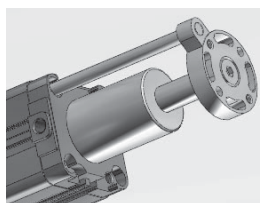

#### Option /M

= Always Female Piston Rod with Flange and Telescopic Magnetic Holder

### RT230...I

Cyl. Ø	Cylinder "0" stroke (g)	Increase per mm stroke (g)	Moving parts "0" stroke (g)	Increase per mm stroke (g)
40	374	3,9	137	1,75
50	552	5,07	225,5	2,37
63	871	6,34	349	2,75

### RT233...

Cyl. Ø	Cylinder "0" stroke (g)	Increase per mm stroke (g)	Moving parts "0" stroke (g)	Increase per mm stroke (g)
40	405	3,9	168	1,75
50	583	5,07	256,5	2,37
63	902	6,34	380	2,75

**Fixing elements for 2-stage telescopic cylinders  $\varnothing 25 \div 63$  mm,  
3-stage  $\varnothing 40 \div 63$  (without fixing screws)**

**Front or rear flange in zinc-plated steel**

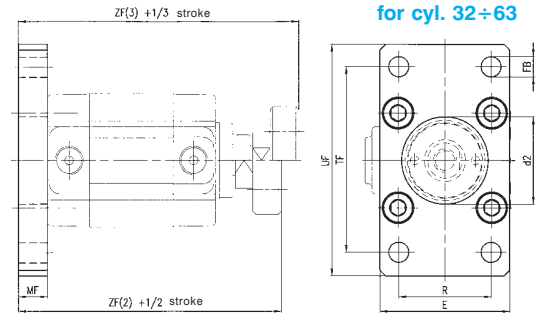
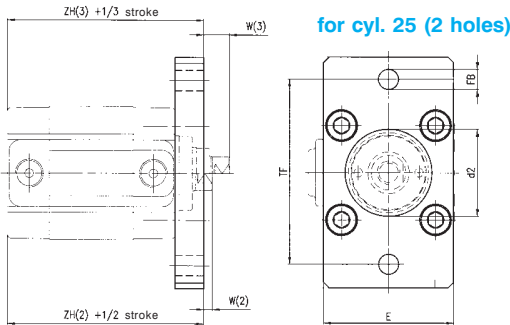

Cyl. Ø	Ød2 H11	E	Ø FB H13	W(2)	W(3)	MF	R JS14	TF JS14	UF	ZF(2)	ZF(3)	ZH(2)	ZH(3)	Mass Kg	Part number
25	24	40	6,6	7	-	10	-	60	76	83	-	58	-	0,18	RTF-12025
32	30	45	7	3	-	10	32	64	80	91	-	68	-	0,20	KF-12032
40	35	52	9	2	12	10	36	72	90	92	102	70	70	0,25	KF-12040
50	44	65	9	3	12	12	45	90	110	100	109	73	73	0,50	RTF-12050
63	52	75	9	3	13	12	50	100	120	104	114	77	77	0,65	RTF-12063

**Angle brackets in zinc-plated steel**

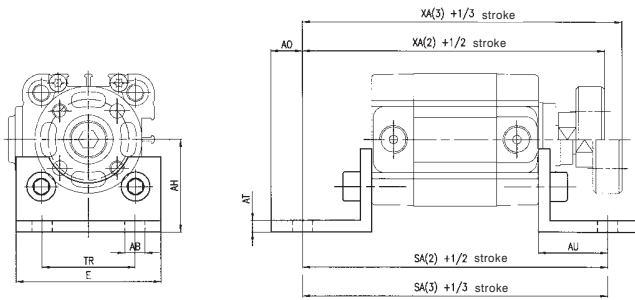

Cyl. Ø	ØAB H13	AH JS15	AO max	AT	AU ±0,2	E max	SA(2)	SA(3)	TR	XA(2)	XA(3)	Mass Kg	Part number
25	6,6	30	6	4	16	40	80	-	26	89	-	0,04	RTF-13025
32	7	32	11	4	24	50	106	-	32	105	-	0,07	KF-13032
40	9	36	15	4	28	58	116	116	36	110	120	0,09	KF-13040
50	9	45	15	5	32	70	125	125	45	120	129	0,20	RTF-13050
63	9	50	15	5	32	85	129	129	50	124	134	0,20	RTF-13063

**Female rear hinge in die-cast aluminium with pin in zinc-plated steel**

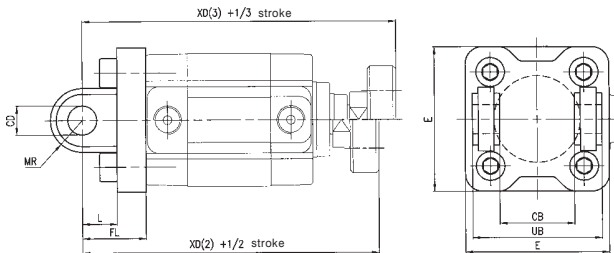

Cyl. Ø	CB H14	ØCD H9	E	FL	L	MR	UB h14	XD(2)	XD(3)	Mass Kg	Part number
32	26	10	48	22	12	11	45	103	-	0,06	KF-10032A
40	28	12	54	25	15	13	52	107	117	0,08	KF-10040A
50	32	12	65	27	15	13	60	115	124	0,15	KF-10050A
63	40	16	75	32	20	17	70	124	134	0,25	KF-10063A

Technical modifications keep in reserve !

(2020/10)

## Male rear hinge in die-cast aluminium

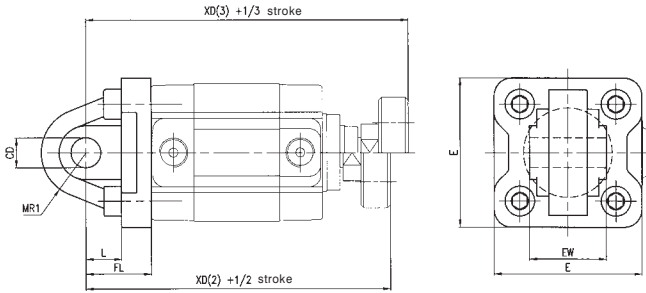

For cyl. ø 25 it is possible to use the male hinge together with the female hinge MF-21025 of microcylinders ISO 6432

Cyl. Ø	ØCD H9	E	EW tol. ±0,2	FL	L	MR1	XD(2)	XD(3)	Mass Kg	Part number
25	8	38	16	20	14	8	93	-	0,027	RPF-11025
32	10	48	26	22	12	15	103	-	0,08	KF-11032
40	12	54	28	25	15	18	107	117	0,10	KF-11040
50	12	65	32	27	15	20	115	124	0,17	KF-11050
63	16	75	40	32	20	23	124	134	0,25	KF-11063

## Articulated male rear hinge in die-cast aluminium

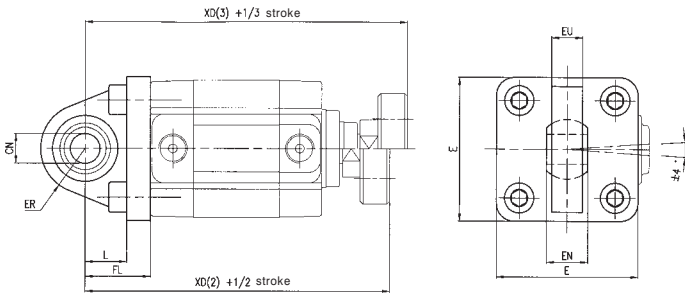

Cyl. Ø	ØCN H9	E	EN	ER	EU	FL	L	XD(2)	XD(3)	Mass kg	Part number
32	10	48	14	15	10,5	22	14	103	-	0,10	KF-11032S
40	12	54	16	18	12	25	16,5	107	117	0,20	KF-11040S
50	12	65	16	20	12	27	17,5	115	124	0,30	KF-11050S
63	16	75	21	23	15	32	21,5	124	134	0,35	KF-11063S

## Counter-hinge 90° in die-cast aluminium

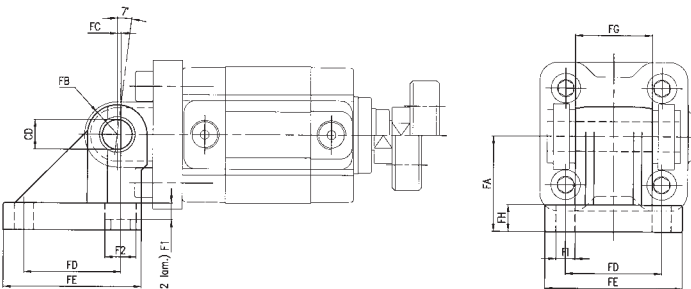

Cil. Ø	ØCD H9	FA J515	FB	FC	FD	FE	FG ±0,2	FH	Ø FI	F1	Ø F2	Mass kg	Part number
32	10	32	10	1,2	32,5	46,5	26	9	6,4	5,5	10,5	0,10	KF-19032
40	12	36	12	2,6	38	51,5	28	9	6,4	5,5	10,5	0,20	KF-19040
50	12	45	12	0,3	46,5	63,5	32	9	8,4	5	13,5	0,30	KF-19050
63	16	50	16	3,3	56,5	73,5	40	10,5	8,4	5	13,5	0,35	KF-19063

Technical modifications keep in reserve !

(2020/10)